

The MISS range of stainless steel sheathed Mineral Insulated (MI) heating cable has been developed to meet the specific need for a cable having a high temperature capability and electrical resistance values needed for long circuit lengths. To meet the requirement, TEC has combined a stainless steel sheath with heating conduc-

tors to enable an operating temperature of 600 °C with resistance values from 2.1 Ω/km down to 36100 Ω/km. MI cables have excellent mechanical strength and are resistant to corrosion. They are series resistance heaters, which must be designed to provide the required heat output.

Construction

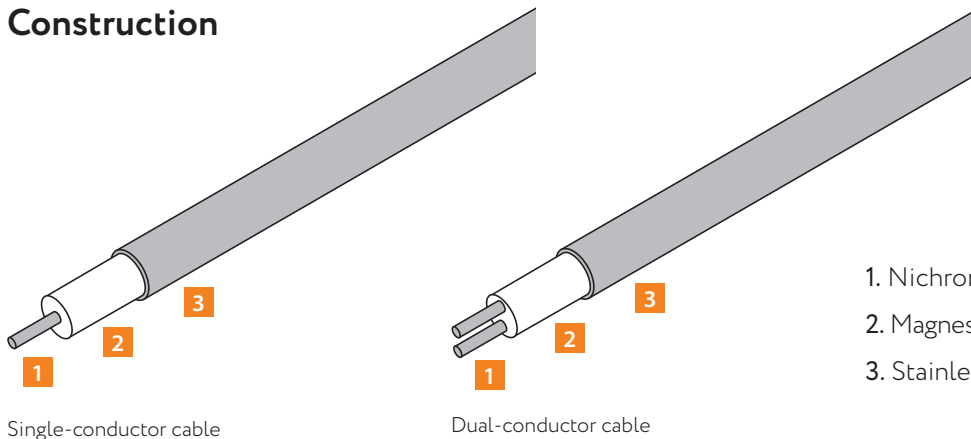

1. Nichrome Conductor
2. Magnesium Oxide Insulation
3. Stainless Steel Sheath

Single-conductor cable

Dual-conductor cable

Application

- Nuclear Industry – Sodium loops
- Metal Forming Industry – Melting of low melt alloys
- Underfloor heating
- Building Industry – Bitumen/asphalt heating
- Tank/vessel Heating

Specification

Heating Cable Ordering Code

Example: MI SS-B 16N12220/60/2520/220/E1
 Digit: ① ② ③ ④ ⑤ ⑥ ⑦

Digit number	Description	Explanation
1	Sheath material	SS
2	Cable configuration	See Table 1
3	Cable reference	See Table 2, 3, 4
4	Cable length	In meter
5	Cable wattage	In Watts
6	Cable voltage	In volt
7	Gland size	See Table 5

Heating Cable Decoding

Example: 1 6 N 12220
 Digit: ① ② ③ ④

Digit number	Description	Explanation
1	Number of conductors	1 or 2
2	Maximum voltage rating	3=300V, 6=600V
3	Conductor material	K, N
4	Cable resistance × 1000	12220=12.22 Ω/m × 1000

Stainless Steel Sheathed Mineral Insulated Heating Cable

Cable Configurations

Table 1

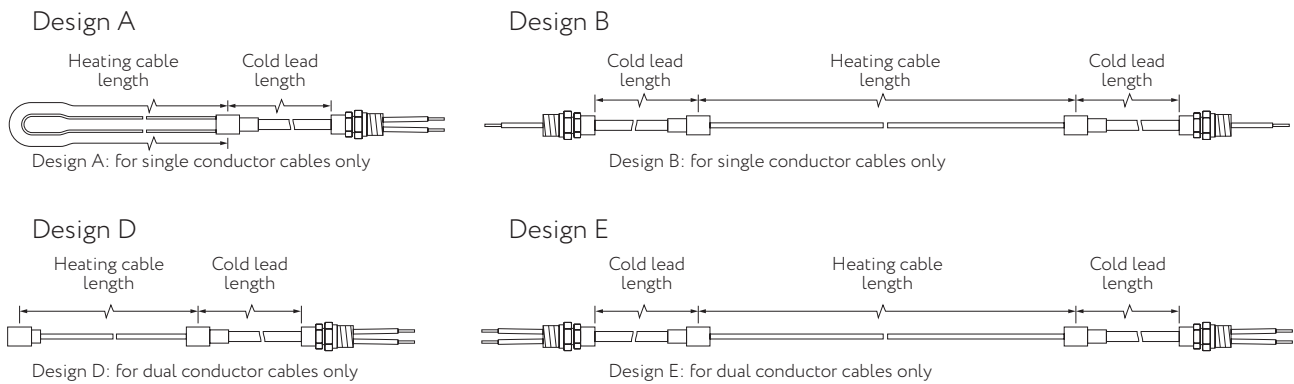

Cable References

Table 2 Single Conductor 600V

Cable ref	Diameter mm	Resist. at 20 °C Ω/m	Nominal Length m	Nominal Weight kg/km
16C2.1	6.8	0.0021	130	218.0
16C3.4	5.9	0.0034	170	158.1
16C5.3	5.3	0.0053	210	121.8
16C8.5	4.7	0.0085	195	92.4
16C13	4.3	0.013	240	74.3
16C21	4.0	0.021	210	65.4
16K40	5.8	0.04	170	154.9
16K50	5.4	0.05	200	131.9
16K60	5.2	0.06	210	119.9
16K80	4.8	0.08	190	99.4
16K100	4.7	0.1	195	91.9
16K120	4.5	0.12	210	82.2
16N160	6.5	0.16	140	193.9
16N200	5.9	0.2	170	159.7
16N250	5.3	0.25	210	128.9
16N400	4.7	0.4	200	95.9
16N500	4.5	0.5	215	86.0
16N630	4.3	0.63	235	76.6
16N1000	3.9	1.0	290	60.9
16N1600	3.6	1.6	335	50.8
16N2500	3.4	2.5	300	45.5
16N2800	3.4	2.8	300	45.3
16N3300	3.4	3.3	300	45.1
16N4000	3.2	4.0	335	39.9
16N5200	3.2	5.2	335	39.6
16N6300	3.2	6.3	335	39.0
16N10000	3.2	10	335	38.7

HEATING CABLE



SST GmbH
i_Park Tauberfranken 18 97922
Lauda-Königshofen, Germany

+49 9343 9809100
info@sst-international.com

Table 3 Dual Conductor 600V

Cable ref	Diameter	Resist. at 20 °C	Nominal Length	Nominal Weight
	mm	Ω/m	m	kg/km
26C8.4	9.8	0.0084	60	400.3
26C13.4	8.7	0.0134	75	308.6
26C21	7.9	0.021	95	246.9
26C34	7.3	0.034	110	208.1
26C54	6.3	0.054	145	153.9
26C85	5.6	0.085	185	120.8
26C130	5.3	0.13	215	104.8
26K180	7.9	0.18	95	255.9
26K260	7.4	0.26	105	220.5
26K360	6.8	0.36	130	180.8
26K500	6.4	0.5	145	159.3
26K650	5.9	0.65	165	131.3
26K1000	5.7	1.0	175	124.4
26K1300	6.2	1.3	150	147.3
26K2000	5.8	2.0	170	125.9
26K3300	5.4	3.3	205	109.1
26N4600	5.8	4.6	170	130.3
26N8000	5.4	8.0	205	111.5
26N13000	5.0	13.0	140	95.0
26N27000	4.8	27.0	150	87.1
26N40000	4.6	40.0	160	79.7
26N60000	4.4	60.0	175	72.8
26N72000	4.2	72.0	190	66.3

Table 4 Dual Conductor 300V

Cable ref	Diameter	Resist. at 20 °C	Nominal Length	Nominal Weight
	mm	Ω/m	m	kg/km
23K210	5.4	0.21	200	118.5
23K300	5.0	0.3	240	99.4
23K400	4.8	0.4	250	90.2
23K480	4.8	0.48	250	89.4
23K650	4.6	0.65	200	82.9
23K1000	4.1	1.0	210	64.8
23K1300	3.8	1.3	240	55.4
23K2000	5.0	2.0	235	97.2
23K2400	4.8	2.4	250	89.3
23K3000	4.6	3.0	200	80.5
23N4600	4.8	4.6	250	89.6
23N7500	4.6	7.5	200	80.0
23N11200	4.4	11.2	180	74.0
23N14000	4.2	14.0	200	67.4
23N18000	3.8	18.0	240	55.1
23N26000	3.6	26.0	270	49.2
23N40000	3.4	40.0	300	43.8
23N50000	3.4	50.0	300	43.7
23N60000	3.4	60.0	300	43.6
23N72000	3.4	72.0	300	43.6

Note: For the required voltage 600 V above application, please contact us.

Stainless Steel Sheathed Mineral Insulated Heating Cable

Gland Size

Table 5

Max. voltage (V)	Design A, D, E			Design B		
	Max. current (amps)	Gland size (English)	(Metric)	Max. current (amps)	Gland size (English)	(Metric)
600	15	E1	M1	20	E1	M1
600	20	E1	M1	25	E1	M1
600	30	E2	M2	40	E2	M2
600	50	E2	M2	70	E2	M2
600	70	E2	M2	100	E2	M2

Note 1: E1 stands for 1/2" NPT; E2 stands for 3/4" NPT; M1 stands for gland diameter M20; M2 stands for gland diameter M25. Stands model shall be advised properly while design.

Note 2: 2-meter-long cold lead is supplied with heating cable. For special requirement, please contact us.

Corrosion Resistance

Table 6

Substance	Recommendation
Sulphuric Acid	Not Recommended
Hydrochloric Acid	Not Recommended
Hydrofluoric Acid	Not Recommended
Phosphoric Acid	Not Recommended
Nitric Acid	Check for Specific Data
Organic Acid	Suitable under Most Conditions
Alkalis	Acceptable
Sea Water	Not Recommended
Chloride	Not Recommended

Explosion Proof

MISS heating cables can be used in C1D2 explosion-proof area, for detailed design, contact us for further assistance.

Approval

ATEX; IECEx



Manufacturer

JIUSHENG ELECTRIC CO., LTD.

No.1000, Xifeng Road, Huzhou Economy&Technology Developing Area, Huzhou, Zhejiang, China

Supplier

SST GmbH

i_Park Tauberfranken 18, 97922, Lauda-Königshofen, Germany