

The MICU range of copper sheathed Mineral Insulated (MI) heating cable has been developed to meet the specific need for a cable having a high temperature capability and electrical resistance values needed for long circuit lengths. To meet the requirement, TEC has combined a copper sheath with heating conductors to enable an operating temperature of 250 °C with resistance values from 0.68 Ω/km down to 2000 Ω/km.

However, an HDPE outer sheath must be used when the cable is used in special situations, such as corrosion resistance or burying or snow melting application. HDPE jacketed copper-sheathed heating cables (MIHC) have an operating temperature of 90 °C. MI cables have excellent mechanical strength and are resistant to corrosion. They are series resistance heaters which must be designed to provide the required heat output.

## Construction

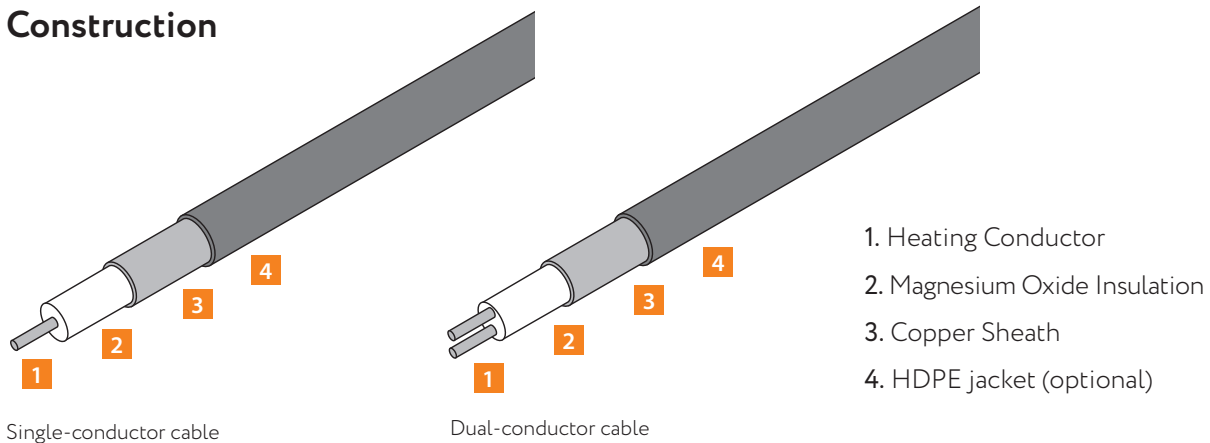

## Application

Bare copper-sheathed heating cable	Max. power output (W/m)
De-icing of metal gutters and downspouts	49
De-icing of nonmetallic gutters and downspouts	16
Process temperature maintenance (pipes and vessels)	59
Freeze protection of metal pipes and vessels	59
Snow melting on metal roofs	49
HDPE jacketed copper-sheathed heating cable	
Freeze protection of metal pipes and vessels	26
Freeze protection of nonmetallic pipes and vessels	13
Snow melting in road-grade asphalt slab	82
Snow melting on nonmetal roof	26
De-icing of metal gutters and downspouts	26
De-icing of nonmetallic gutters and downspouts	16
Floor warming in concrete slab	33
Frost heave prevention in sand under freezer or arena floor	23
Snow melting in concrete and mastic asphalt slab	99

**Note:** When designing heating cables for pipe and vessel tracing, the 'Max. power output' values may have to be decreased to ensure that the sheath temperature does not exceed the maximum exposure temperature or the autoignition temperature of the area (hazardous location only).

# Copper Sheathed Mineral Insulated Heating Cable

## Specification

### Heating Cable Ordering Code

Example: MI CU-B 16K3200/60/2520/220/E1  
 Digit: ① ② ③ ④ ⑤ ⑥ ⑦

Digit number	Description	Explication
1	Sheath material	CU
2	Cable configuration	See Table 1
3	Cable reference	See Table 2, 3, 4
4	Cable length	In meter
5	Cable wattage	In Watts
6	Cable voltage	In volt
7	Gland size	See Table 5

### Heating Cable Decoding

Example: 1 6 K 3200  
 Digit: ① ② ③ ④

Digit number	Description	Explication
1	Number of conductors	1 or 2
2	Maximum voltage rating	3=300V, 6=600V
3	Conductor material	C, K
4	Cable resistance × 1000	3200=3.22 Ω/m × 1000

## Cable Configurations

Table 1

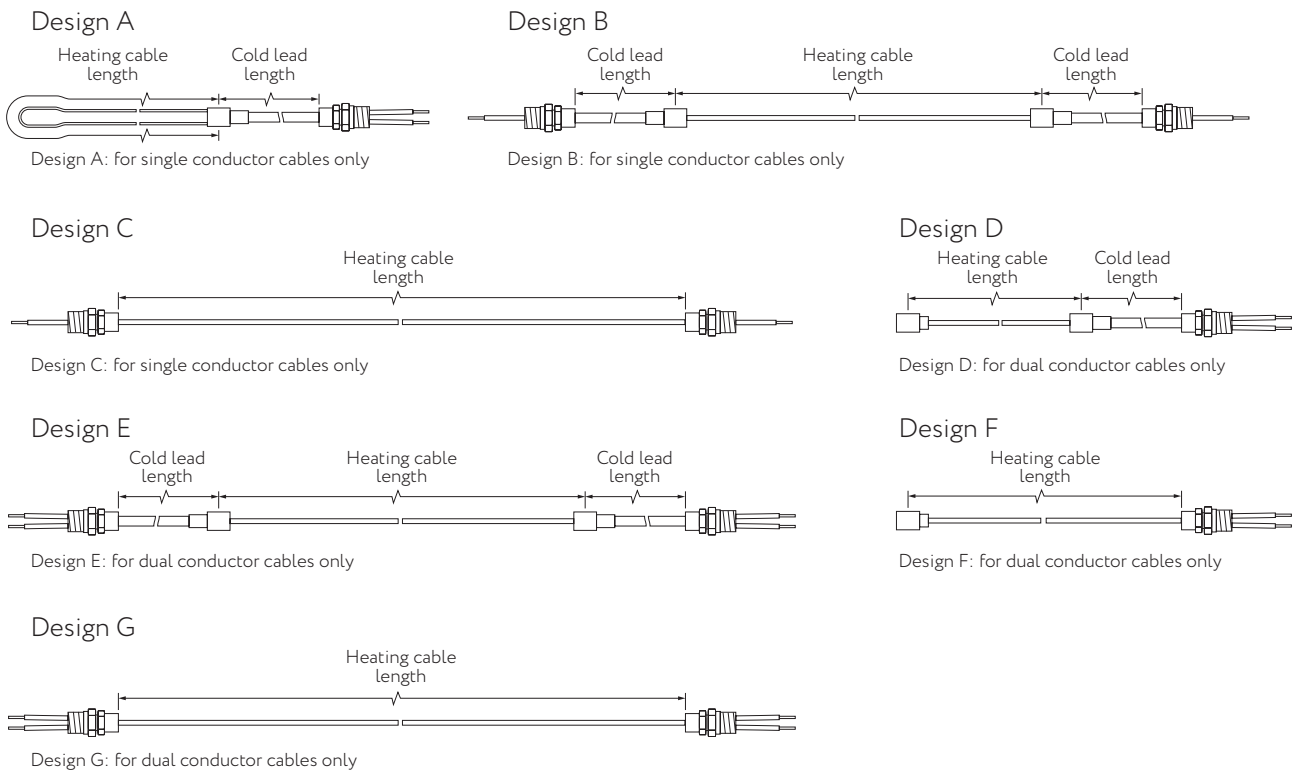

**Note:** Design C, F, G suitable for sheath temperature below 65 °C application.

# MI Heating Cable MICU

## Cable References

**Table 2 Single Conductor 600 V**

Cable ref	Diameter	OD of HDPE Jacket	Resist. at 20 °C	Nominal Length	Nominal Weight With jacket
	mm	mm	Ω/m	m	kg/km
16C1.7	7.3	9.7	0.0017	550	314.1
16C2.2	7.0	9.4	0.0022	600	282.3
16C2.9	6.4	8.8	0.0029	550	237.2
16C4	5.9	8.3	0.004	600	196.2
16C7	5.3	7.7	0.007	245	157.6
16C11	4.9	7.3	0.011	280	134.7
16C13	4.6	7	0.013	325	119.8
16C17	4.6	7	0.017	325	118.5
16C21	4.6	7	0.021	325	115.3
16C25	4.6	7	0.025	325	116.2
16C33	4.6	7	0.033	325	113.9
16C40	3.4	5.8	0.04	410	70.5
16C63	3.2	5.6	0.063	450	62.8
16K80	5.3	7.7	0.08	245	158.3
16K100	5.2	7.6	0.1	270	146.5
16K140	4.9	7.3	0.14	300	130.7
16K197	4.45	6.85	0.197	350	109.6
16K220	4.5	6.9	0.22	330	113.8
16K315	4.3	6.7	0.315	370	108.1
16K345	4.2	6.6	0.345	380	103.5
16K450	4.0	6.4	0.45	430	94.6
16K630	4.0	6.4	0.63	430	92.2
16K800	3.5	5.9	0.8	390	74.5
16K1280	3.7	6.1	1.28	350	78.5
16K2000	3.6	6	2.0	370	75.4

Table 3 Dual Conductor 600 V

Cable ref	Diameter	Resist. at 20 °C	Nominal Length	Nominal Weight
	mm	Ω/m	m	kg/km
26C3.4	12.9	0.0034	150	849.7
26C4.4	12.2	0.0044	160	748.6
26C5.8	11.3	0.0058	170	637.5
26C8.6	9.90	0.0086	180	489.5
26C11.4	9.30	0.0114	200	498.9
26C13.8	9.00	0.0138	210	399.2
26C17.2	8.60	0.0172	220	363.3
26023	8.00	0.023	250	314.7
26C34.4	7.50	0.0344	280	275.4
26C49.2	7.10	0.0492	300	246.5
26K240	9.90	0.24	180	489.4
26K320	9.30	0.32	200	498.6
26K384	9.00	0.384	210	399.2
26K480	8.60	0.48	220	363.2
26K640	8.00	0.64	250	314.7
26K960	7.50	0.96	280	275.3

Table 4 Dual Conductor 300 V

Cable ref	Diameter	Resist. at 20 °C	Nominal Length	Nominal Weight
	mm	Ω/m	m	kg/km
23C3.4	12.4	0.0034	200	797.2
23C4.4	11.3	0.0044	220	660.6
23C5.8	10.4	0.0058	240	555.8
23C8.6	9.00	0.0086	260	417.6
23C11.4	8.40	0.0114	280	361.3
23C13.8	8.00	0.0138	300	326.9
23C17.2	7.60	0.0172	320	294.1
23023	7.10	0.023	340	256.2
23C34.4	6.60	0.0344	360	220.5
23C49.2	6.20	0.0492	380	194.4
23K160	10.4	0.16	220	556.4
23K240	9.00	0.24	240	417.5
23K320	8.40	0.32	265	361.0
23K384	8.00	0.384	280	326.9
23K480	170	0.48	300	300.6
23K640	710	0.64	320	256.3
23K960	6.50	0.96	350	214.7

**Note:** For the required voltage 600 V above application, please contact us.

# MI Heating Cable MICU

## Gland Size

**Table 5**

Max. voltage (V)	Design A, D, E			Design B			Design C, F, G		
	Max. current (amps)	Gland size (English)	(Metric)	Max. current (amps)	Gland size (English)	(Metric)	Max. current (amps)	Gland size (English)	(Metric)
600	15	E1	M1	20	E1	M1	15	E1	M1
600	20	E1	M1	25	E1	M1	20	E1	M1
600	30	E2	M2	40	E2	M2	30	E2	M2
600	50	E2	M2	70	E2	M2	50	E2	M2
600	70	E2	M2	100	E2	M2	70	E2	M2

**Note 1:** E1 stands for 1/2" NPT; E2 stands for 3/4" NPT; M1 stands for gland diameter M20; M2 stands for gland diameter M25. Stands model shall be advised properly while design.

**Note 2:** 2-meter-long cold lead is supplied with heating cable. For special requirement, please contact us.

## Corrosion Resistance

**Table 6**

Substance	MICU	MIHC
Sulphuric Acid	Not Recommended	Good-Excellent
Hydrochloric Acid	Not Recommended	Good-Excellent
Hydrofluoric Acid	Acceptable	Acceptable
Phosphoric Acid	Acceptable	Acceptable
Nitric Acid	Not Recommended	Acceptable
Organic Acid	Acceptable	Not Recommended
Alkalis	Acceptable	Acceptable
Sea Water	Not Recommended	Acceptable
Chloride	Check for specific data	Acceptable

## Explosion Proof

MICU/MIHC heating cables can be used in C1D2 explosion-proof area, for detailed design, contact us for further assistance.

## Approval

ATEX; IECEx



## Manufacturer

JIUSHENG ELECTRIC CO., LTD.

No.1000, Xifeng Road, Huzhou Economy&Technology Developing Area, Huzhou, Zhejiang, China

## Supplier

SST GmbH

i\_Park Tauberfranken 18, 97922, Lauda-Königshofen, Germany